

PHILCO Model 625

SERVICE BULLETIN
No. 238



For Members of
RADIO MANUFACTURERS SERVICE
A PHILCO SERVICE PLAN

Model 625

Type Circuit: Superheterodyne, with preselector R.F. amplifier, and pentode output (3 watts); built in connections for Philco All-wave aerial; aerial selector built into and operated by wave-band switch.

Power Supply: Alternating Current. Voltage and frequency as specified on chassis nameplate.

Tubes Used: 1 type 78, R.F.; 1 type 6A7, Detector-Oscillator; 1 type 78, I.F.; 1 type 75, 2d Detector and 1st A.F.; 1 type 42 Output; 1 type 80 Rectifier.

Wave Bands: Three—(1) standard (with some Police); (2) Police, Aircraft and Amateur; (3) Short-wave.

Coverage of Each Band: Band 1, 540-1720 K.C.; Band 2, 1750 to 5800 K.C. (1.75-5.8 megacycles); Band 3, 5700-18000 K.C. (5.7 to 18.0 megacycles).

Tuning Drive: Two-speed gear drive, ball bearing. 50 to 1 ratio for slow-speed tuning.

Program Control: 3-position, with bass compensation effective in first position.

Intermediate Frequency: 460 K.C.

Power Consumption: 65 watts.

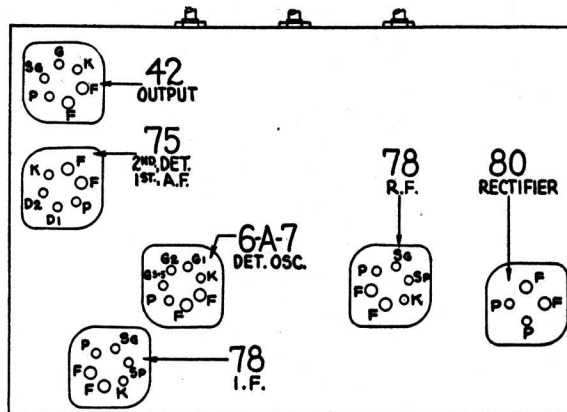

Fig. 1. Tube Sockets as viewed from bottom.

Tube Socket Voltages Measured to Ground

Tube	78 R.F.	6A7 Det. Osc.	78 I.F.	75 2d Det.	42 Output
Point P	258	258	258	153	243
SG	95	95	95	...	258
K	2.85

6A7: G₃ & 5 = 173

Above voltages were obtained by using a PHILCO type 025 Circuit Tester (or 048A All-purpose Tester), using test leads applied to underside of chassis. Volume control at maximum; dial at 55; waveband switch counter-clockwise (band 1). Use Fig. 1 for test points. Line voltage 115 volts.

Power Transformer Data

Terminals	A.C. Volts	Current	Circuit	Color
1-2	120	Primary	White
3-5	680	65 M.A.	Secondary	Yellow
6-7	5.0	2.0 A.	Fil. Rect.	Blue
8-9	6.3	2.0 A.	Filaments	Black
4	Center Tap of 3-5	Yellow, Green Tracer

Adjusting Compensating Condensers Model 625

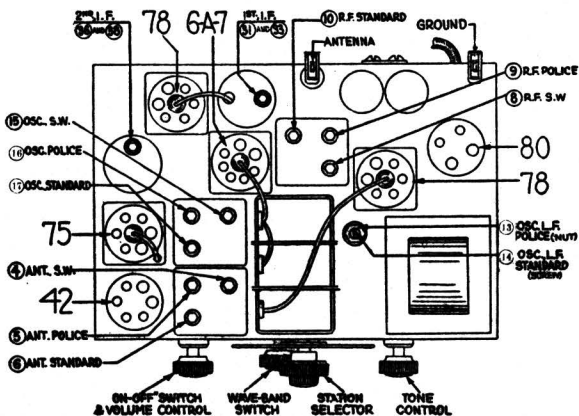

Fig. 2. Locations of Compensating Condensers

The adjustment of the compensating condensers in Model 625 requires a signal generator covering the broadcast and police band, and also one capable of producing a signal at certain frequencies in the short wave band. Philco Model 088 All-wave signal generator is ideal for these requirements. Or you can use the Philco Model 024 or 048A instrument for the broadcast frequencies, and the Model 091 crystal controlled short wave signal generator for the "short-wave" frequencies. The location of all compensating condensers is shown in Fig. 2. An output meter is also needed, such as in Philco Model 025.

Adjustment of I. F.

1. Remove the antenna connection from the receiver, disconnect the grid clip from the first detector (type 6A7 tube), and connect the "ANT" output terminal of the broadcast signal generator to the grid cap of this tube; connect the "GND" terminal of the signal generator to the "GND" terminal of the receiver.

2. Connect the 0 to 80 volt range of the output meter in the Philco 048A or 025 unit to the plate and cathode of the output tube or to the two bottom prongs of the speaker plug.

PHILCO
Service Bulletin

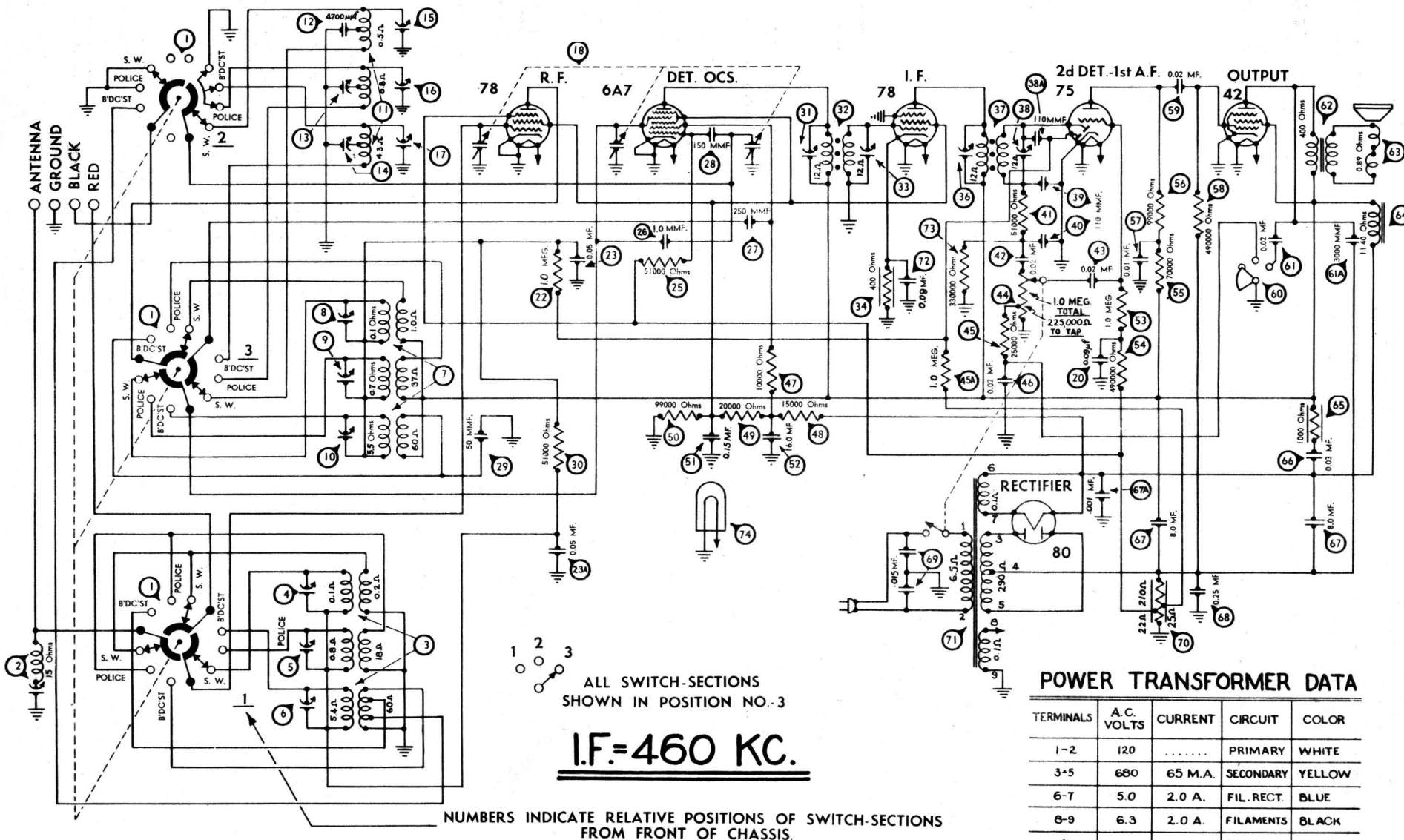

Fig. 3. Schematic Diagram of Model 625

POWER TRANSFORMER DATA

TERMINALS	A.C. VOLTS	CURRENT	CIRCUIT	COLOR
1-2	120	PRIMARY	WHITE
3-5	680	65 M.A.	SECONDARY	YELLOW
6-7	5.0	2.0 A.	FIL. RECT.	BLUE
8-9	6.3	2.0 A.	FILAMENTS	BLACK
4	CENTER TAP OF 3-5	YELLOW, GREEN TRACER

3. Adjust the signal generator to a frequency of 460 K.C. Place the receiver in operation with the dial turned to the low frequency end of the standard broadcast band, wave band switch to extreme left (clockwise), and have the volume control adjusted near its maximum setting. Adjust the signal generator attenuator for approximately half-scale reading of the output meter.

4. The I.F. compensating condensers are located at the tops of the I.F. coil shields. The primary is adjusted by turning the screw in top and the secondary by the nut. Adjust condensers ⑩ and ⑪ (2d I.F. primary and secondary) for maximum reading in the output meter, and then condensers ⑫ and ⑬ (1st I.F. primary and secondary).

Adjustment of Wave-Trap

1. Connect the signal generator leads to the antenna and ground terminals of the receiver. Replace the grid clip on the 6A7 grid cap.

2. With the wave-band switch of the receiver still in the extreme left (standard band), (540-1720 K.C.), turn the station selector to 55.

3. With the signal generator in operation at 460 K.C., adjust the wave-trap ② condenser until a MINIMUM reading is obtained on the output meter. The Philco fibre wrench, part No. 3164, is used for this adjustment. The wave-trap compensator is reached from rear of chassis.

Adjustment of High and Low Frequency Compensators

1. With the wave-band switch still at Range No. 1 (broadcast band), set the dial at 1700 K.C. Set the signal generator at this frequency and adjust compensators ⑭, ⑮ and ⑯ for maximum output. These are the oscillator, antenna, and R.F. "standard" compensators respectively.

2. Tune the receiver and the signal generator to 600 K.C. and adjust compensator ⑰ (screw) for maximum output. This is the oscillator L.F. standard compensator.

3. Turn the wave-band switch to the second (middle) position. Set the dial at 3.6 M.C., at which point the fundamental of the 091 signal will be heard. If the Model 088 signal generator is being used, set it at 3.6 M.C. Adjust condensers ⑱, ⑲ and ⑳ in succession. These are the oscillator, antenna and R.F. police band adjustments.

4. Turn the tuning dial to 1.8 M.C., and set the signal generator (Model 024 or Model 088) at 1800 K.C. Adjust condenser ㉑ (Osc. L.F., police) (nut), to maximum signal.

5. Turn the wave-band switch to Band 3 (extreme right) and adjust the station selector to 18.0 megacycles. Set the signal generator at 18 M.C. By means of the Philco wrench, part No. 3164, adjust the oscillator S.W., antenna S.W. and R.F. S.W. compensators for maximum reading in the output meter. These are numbered ㉒, ㉓ and ㉔ respectively in figure No. 2.

**Stop
LOSING TIME
ON AERIAL JOBS**

**USE THIS BRAND NEW TIME AND
TROUBLE SAVER FOR SERVICEMEN**

PHILCO *Aerial Mast* KIT

Part No. 45-2127

The new Philco Aerial Mast solves another of your biggest problems—a high-grade aerial mast outfit, ready to put together, and adaptable to any type of roof. Eliminates the trouble of selecting a suitable mast for each job, buying guy wire, fittings, etc., separately, and then spending hours making the installation.

The Philco Mast Kit consists of an 8-foot tubular steel mast in two sections, with a sturdy coupling to connect the sections; a top fitting, 30 feet of stranded guy wire and two porcelain strain insulators. Packed in a strong carton, with full instructions. Three types of mounting for securing base of mast are available to suit any type of roof: For flat roof, Part No. 28-3759; for peaked roof, Part No. 28-3758; for sloping roof, Part No. 28-3757.

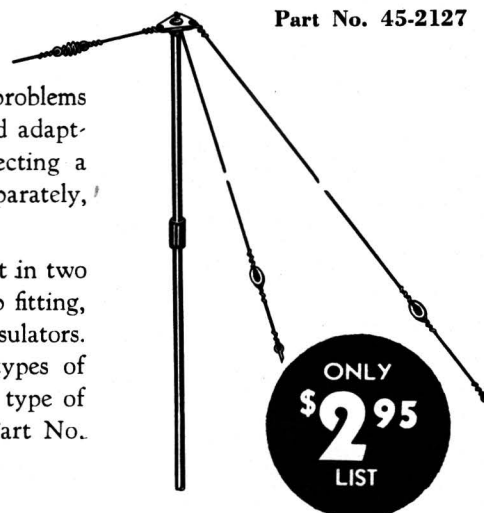

Copyrighted 1936. All rights reserved.

PHILCO
Parts and Service Division

Jan. 15, 1936

Printed in U. S. A.